

## ALUTRUSS TRILOCK QPAL-33 3-way corner V right

3-point truss system

Art. No.: 60301870

GTIN: 4026397092264

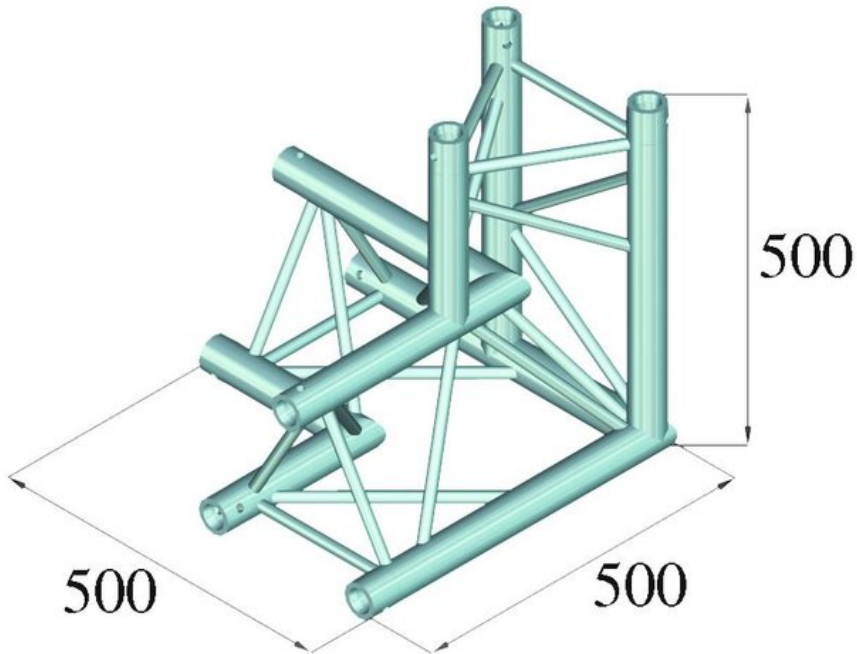

**The article is no longer in our assortment.**

### Features:

- High-quality aluminum-tubes with 50 mm in diameter
- Easy installation
- Low weight
- For exhibition and shop installers, discotheque and theatre installations

### Logistic

EAN / GTIN: 4026397092264

Weight: 6,74 kg

Length: 0.50 m

Width: 0.50 m

Height: 0.50 m

### Technical specifications:

Main chords: 50 x 2 mm

Alloy: AlMgSi 0.5

Welding material: AlMg 5

Welding technique: TIG-welding