

A

B

C

D

1

2

3

4

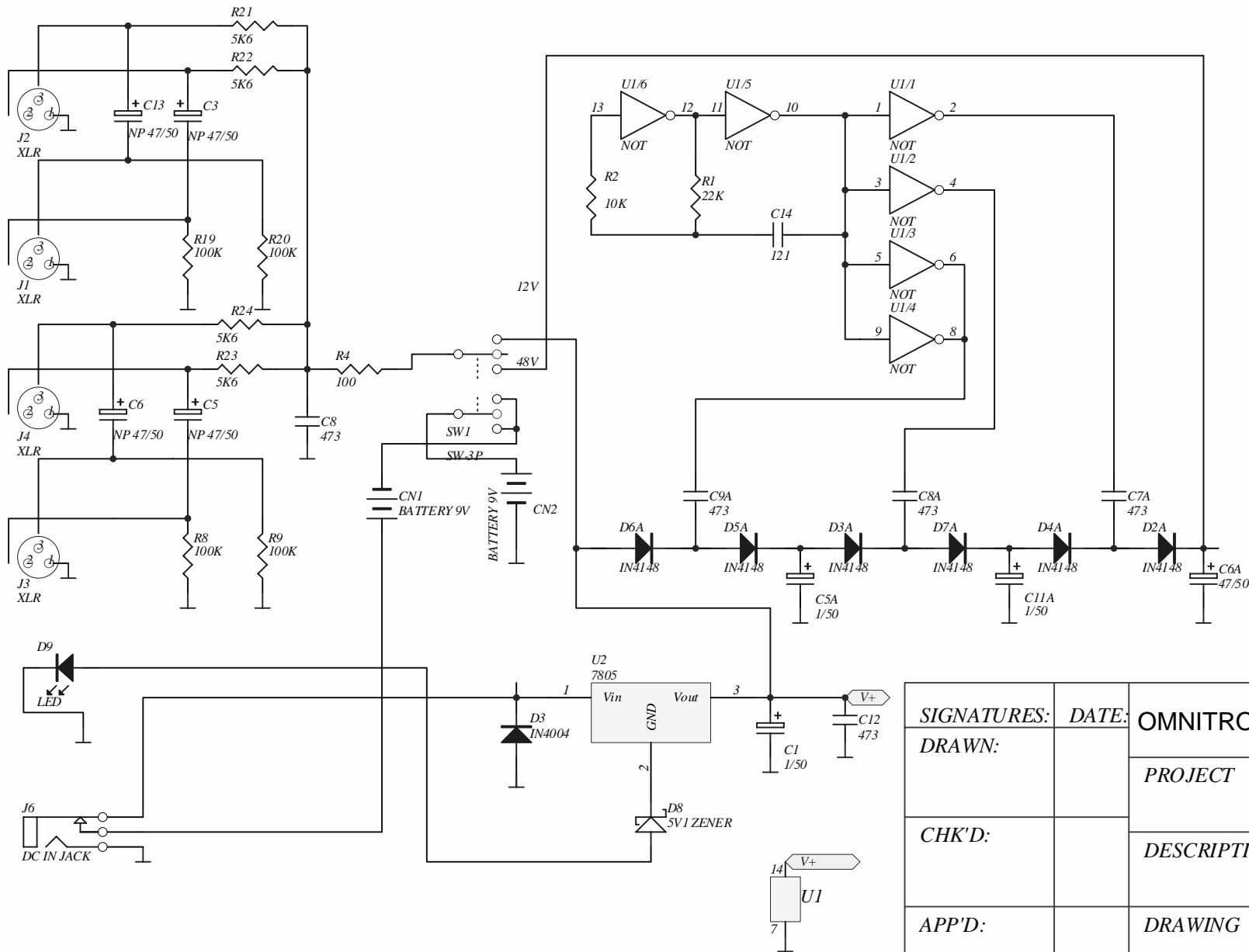

<b>SIGNATURES:</b>	<b>DATE:</b>	<b>OMNITRONIC LH-051, No. 10355051</b>
<b>DRAWN:</b>		<b>PROJECT NAME:</b>
<b>CHK'D:</b>		<b>DESCRIPTION:</b>
<b>APP'D:</b>		<b>DRAWING NO:</b>
<b>SHEET 1 OF 1</b>		<b>REV. 1</b>

1

2

3

4